



Taper Naben / Hubs & Adaptors

Taper-Einschweißnabe WM / Weld-on-Hubs Mat. C45

Typ	A	B	C	D	E	F
WM 1108	58	50	48	23	8	10
WM 1210	70	60	58	26	9	10
WM 1215	70	60	58	38	10	11
WM 1610	83	70	68	26	9	10
WM 1615	83	70	68	38	10	11
WM 2012	95	90	88	32	12	12
WM 2517	127	110	108	44	19	13
WM 3020	152	130	125	50	20	15
WM 3030	152	130	125	76	25	19
WM 3525	184	155	151	64	32	25
WM 3535	184	155	151	89	32	25
WM 4040	225	195	187	102	32	32
WM 4545	254	220	213	114	38	38
WM 5050	278	242	228	127	38	38
WM 6050	350	320	300	127	35	55

Taper-Einschweißnabe WH / Weld-on-Hubs Mat. C45

Typ	A	B	C	D	E	F
WH 1210	70	65	64,5	25	9	10
WH 1610	80	75	74,5	25	9	10
WH 2012	95	90	89,5	32	12	12
WH 2517	115	110	109,5	44	19	15
WH 3020	145	140	139,5	50	20	15
WH 3525	190	180	179,5	65	25	25
WH 4040	200	190	189,5	101	32	30

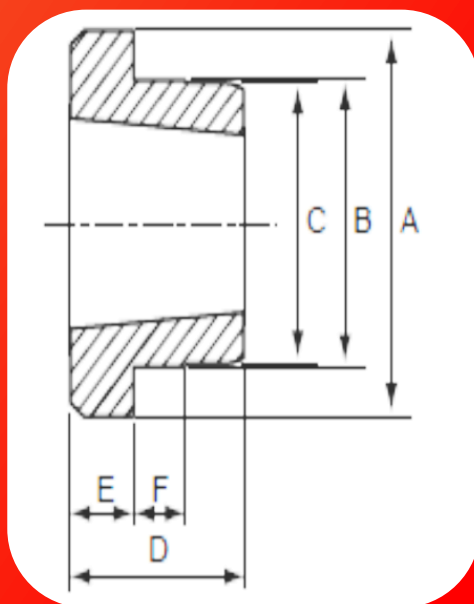

Taper Naben / Hubs & Adaptors

Taper-Zwischenhülsen
Adaptors Mat. GG22

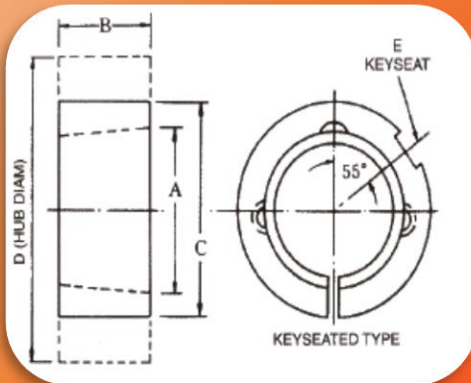

Typ	Keilnut keyway	B	C
1008 AM		22	45
1008 BM	5 x 2,5	22	45
1210 AM		25	60
1210 BM	6 x 3,0	25	60
1615 AM		38	70
1615 BM	10 x 4,0	38	70
2517 AM		45	105
2517 BM	16 x 4,0	45	105
3030 AM		76	130
3030 BM	20 x 5,0	76	130
3535 AM		89	160
3535 BM	22 x 5,0	89	160
4040 AM		102	185
4040 BM	24 x 5,0	102	185

Taper-Anschraubnaben
Screw-on-Hubs Mat. GG22

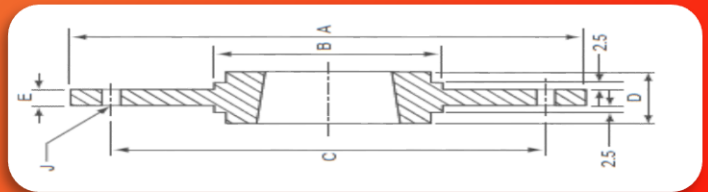

Typ	A	B	C	D	E	J
						Nr. x Ø
SM 1210 - 0	140	90		25	6,5	
SM 1210 - 1	120	80	100	25	5,5	6 x 8,5
SM 1210	180	90	135	25	6,5	6 x 7,5
SM 1610	130	90	110	25	6,5	6 x 8,5
SM 1610 - 1	200	110	150	25	9	6 x 7,5
SM 1615	200	110	150	38	7,5	6 x 7,5
SM 2012 - 0	145	100		32	8,5	
SM 2012 - 1	225	140		32	8,5	
SM 2012	270	140	190	32	8,5	6 x 9,5
SM 2517	340	170	240	45	9,5	8 x 11,5
SM 3020 - 0	220	165	190	51	12	8 x 13,5
SM 3020 - 1	430	220	300	51	14	8 x 13,5
SM 3020 - 2	485	250	340	51	14	8 x 13,5

