



Index

V-belt pulleys with solid hub

V-belt pulleys with solid hub

S / SPZ: Dm 50 – 132 mm
----- Dm 140 – 250 mm

A / SPA: Dm 50 – 100 mm
----- Dm 106 – 180 mm
----- Dm 200 – 400 mm
----- Dm 450 – 560 mm

B / SPB: Dm 63 – 112 mm
----- Dm 118 – 180 mm
----- Dm 190 – 300 mm
----- Dm 315 – 800 mm

C: Dm 180 – 280 mm
--- Dm 300 – 560 mm
--- Dm 630 – 1000 mm

BORES, KEYWAYS

SPECIFICATIONS

DIMENSIONS, FITS ISO TOLERANCES

MATERIAL, BALANCING, PACKING



S / SPZ: Dm 50 – 132

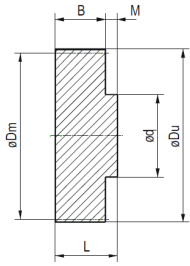

Type 1

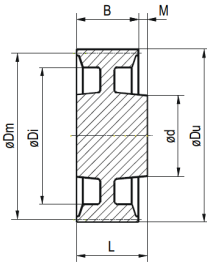

Type 2

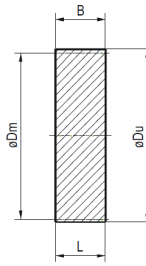

Type 6

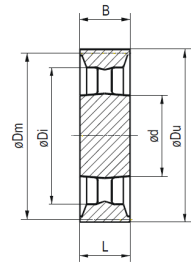

Type 7

Code	Dm	Grooves Spor	Pulley Skive	Bore Udboring	Du	B	d	L	Di	M	N	Unbalance Ubalance	Weight Vægt	Matr.
EDB	mm	no./antal	type	mm	mm	mm	mm	mm	mm	mm	mm	gcm (max)	kg	DIN1691/93
31.0050.01	50	1	1 ●	20	57	16	32	28	-	12	-	3,8	0,3	GG-20
31.0050.02	50	2	1 ●	20	57	28	35	35	-	7	-	5,0	0,4	GG-25
31.0050.03	50	3	6 ●	20	57	40	-	40	-	-	-	7,5	0,6	GG-25
31.0056.01	56	1	1 ●	20	63	16	32	28	-	12	-	5,0	0,4	GG-20
31.0056.02	56	2	1 ●	25	63	28	40	35	-	7	-	7,5	0,6	GG-25
31.0056.03	56	3	6 ●	25	63	40	-	40	-	-	-	10,0	0,8	GG-25
31.0063.01	63	1	1 ●	25	70	16	40	28	-	12	-	5,0	0,4	GG-20
31.0063.02	63	2	1 ●	25	70	28	40	35	-	7	-	7,5	0,6	GG-25
31.0063.03	63	3	6 ●	25	70	40	-	40	-	-	-	11,3	0,9	GG-25
31.0071.01	71	1	2 ○	25	78	16	40	28	-	12	-	5,0	0,4	GG-20
31.0071.02	71	2	1 ●	25	78	28	48	35	-	7	-	11,3	0,9	GG-25
31.0071.03	71	3	6 ●	30	78	40	-	40	-	-	-	15,0	1,2	GG-25
31.0075.01	75	1	2 ○	25	82	16	40	28	-	12	-	6,3	0,5	GG-20
31.0075.02	75	2	1 ●	25	82	28	50	35	-	7	-	12,5	1,0	GG-25
31.0075.03	75	3	6 ●	30	82	40	-	40	-	-	-	15,0	1,2	GG-30
31.0080.01	80	1	2 ○	25	87	16	40	28	-	12	-	6,3	0,5	GG-20
31.0080.02	80	2	2 ○	30	87	28	48	35	-	7	-	11,3	0,9	GG-25
31.0080.03	80	3	6 ●	38	87	40	-	40	-	-	-	16,3	1,3	GG-25
31.0085.01	85	1	2 ○	25	92	16	40	28	-	12	-	6,3	0,5	GG-20
31.0085.02	85	2	2 ○	30	92	28	48	35	-	7	-	13,8	1,1	GG-25
31.0085.03	85	3	6 ●	38	92	40	-	40	-	-	-	21,3	1,7	GG-25
31.0090.01	90	1	2 ○	25	97	16	40	28	-	12	-	8,8	0,7	GG-20
31.0090.02	90	2	2 ○	30	97	28	48	35	-	7	-	15,0	1,2	GG-25
31.0090.03	90	3	6 ●	38	97	40	-	40	-	-	-	21,3	1,7	GG-25
31.0095.01	95	1	2 ○	28	102	16	45	28	-	12	-	8,8	0,7	GG-20
31.0095.02	95	2	2 ○	30	102	28	50	35	-	7	-	15,0	1,2	GG-25
31.0095.03	95	3	6 ●	38	102	40	-	40	-	-	-	23,8	1,9	GG-25
31.0100.01	100	1	2 ○	28	107	16	45	28	-	12	-	10,0	0,8	GG-20
31.0100.02	100	2	2 ○	30	107	28	50	35	-	7	-	16,3	1,3	GG-25
31.0100.03	100	3	7 ○	38	107	40	60	40	-	-	-	26,3	2,1	GG-25
31.0106.01	106	1	2 ○	28	113	16	45	28	-	12	-	10,0	0,8	GG-20
31.0106.02	106	2	2 ○	30	113	28	48	35	-	7	-	16,3	1,3	GG-25
31.0106.03	106	3	7 ○	38	113	40	62	40	-	-	-	26,3	2,1	GG-25
31.0112.01	112	1	2 ○	28	119	16	45	28	-	12	-	12,5	1,0	GG-20
31.0112.02	112	2	2 ○	30	119	28	48	35	-	7	-	17,5	1,4	GG-25
31.0112.03	112	3	7 ○	38	119	40	62	40	-	-	-	32,5	2,6	GG-25
31.0118.01	118	1	2 ×	28	125	16	45	28	97	12	-	10,0	0,8	GG-20
31.0118.02	118	2	2 ○	30	125	28	48	35	-	7	-	20,0	1,6	GG-25
31.0118.03	118	3	7 ○	38	125	40	62	40	-	-	-	33,8	2,7	GG-25
31.0125.01	125	1	2 ×	28	132	16	45	28	104	12	-	12,5	1,0	GG-20
31.0125.02	125	2	2 ×	30	132	28	50	35	104	7	-	17,5	1,4	GG-25
31.0125.03	125	3	7 ○	38	132	40	62	40	-	-	-	36,3	2,9	GG-25
31.0132.01	132	1	2 ×	28	139	16	45	28	110	12	-	12,5	1,0	GG-20
31.0132.02	132	2	2 ×	30	139	28	50	40	109,5	12	-	18,8	1,5	GG-25
31.0132.03	132	3	7 ×	38	139	40	61	40	112	-	-	30,0	2,4	GG-25

● Solid pulley/Massiv skive ○ Plate pulley/Kropskive × Arm pulley/Egerskive

09-08-1999



S / SPZ: Dm 140 – 250

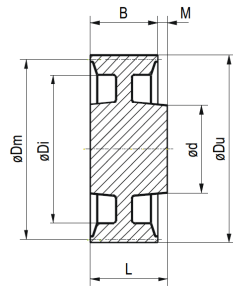

Type 2

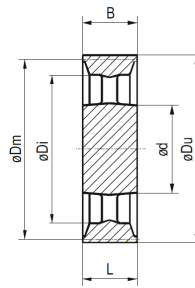

Type 7

Code	Dm	Grooves Spor	Pulley Skive	Bore Udboring	Du	B	d	L	Di	M	N	Unbalance Ubalance	Weight Vægt	Matr.
EDB	mm	no./antal	type	mm	mm	mm	mm	mm	mm	mm	mm	gcm (max)	kg	DIN1691/93
31.0140.01	140	1	2 X	28	147	16	45	28	117	12	-	16,3	1,3	GG-20
31.0140.02	140	2	2 X	38	147	28	61	40	118	12	-	22,5	1,8	GG-25
31.0140.03	140	3	7 X	38	147	40	61	40	117	-	-	31,3	2,5	GG-25
31.0160.01	160	1	2 X	32	167	16	55	32	139	16	-	17,5	1,4	GG-20
31.0160.02	160	2	2 X	38	167	28	61	40	139	12	-	23,8	1,9	GG-25
31.0160.03	160	3	2 X	42	167	40	68	45	139	5	-	36,3	2,9	GG-20
31.0180.01	180	1	2 X	32	187	16	55	32	159	16	-	21,3	1,7	GG-20
31.0180.02	180	2	2 X	38	187	28	61	40	159	12	-	30,0	2,4	GG-25
31.0180.03	180	3	2 X	42	187	40	68	45	159	5	-	40,0	3,2	GG-25
31.0200.01	200	1	2 X	32	207	16	55	32	179	16	-	21,3	1,6	GG-20
31.0200.02	200	2	2 X	38	207	28	62	40	179	12	-	29,3	2,2	GG-20
31.0200.03	200	3	2 X	42	207	40	68	45	179	5	-	45,2	3,4	GG-25
31.0225.01	225	1	2 X	32	232	16	55	32	204	16	-	27,0	1,8	GG-20
31.0225.02	225	2	2 X	38	232	28	61	40	204	12	-	37,5	2,5	GG-20
31.0225.03	225	3	2 X	42	232	40	68	45	204	5	-	51,0	3,4	GG-25
31.0250.01	250	1	2 X	32	257	16	55	32	229	16	-	33,4	2,0	GG-20
31.0250.02	250	2	2 X	38	257	28	61	40	229	12	-	48,4	2,9	GG-20
31.0250.03	250	3	2 X	42	257	40	68	45	229	5	-	61,8	3,7	GG-25



A / SPA: Dm 50 – 100

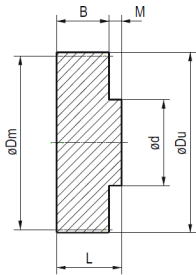

Type 1

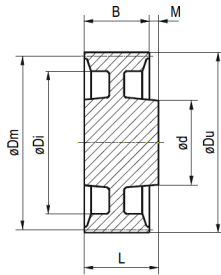

Type 2

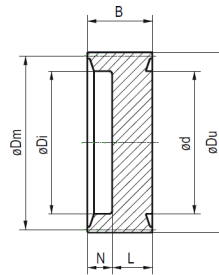

Type 3

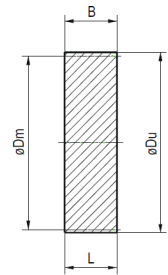

Type 6

Code	Dm	Grooves Spor	Pulley Skive	Bore Udboring	Du	B	d	L	Di	M	N	Unbalance Ubalance	Weight Vægt	Matr.
EDB	mm	no./antal	type	mm	mm	mm	mm	mm	mm	mm	mm	gcm (max)	kg	DIN1691/93
32.0050.01	50	1	2 ○	20	59,5	22	32	35	-	13	-	5,0	0,4	GG-20
32.0050.02	50	2	1 ●	25	59,5	37	40	45	-	8	-	7,5	0,6	GG-25
32.0050.03	50	3	6 ●	25	59,5	52	-	52	-	-	-	8,8	0,7	GG-25
32.0056.01	56	1	2 ○	20	65,5	22	35	35	-	13	-	5,0	0,4	GG-20
32.0056.02	56	2	1 ●	25	65,5	37	40	45	-	8	-	7,5	0,6	GG-25
32.0056.03	56	3	6 ●	25	65,5	52	-	52	-	-	-	10,0	0,8	GG-25
32.0063.01	63	1	2 ○	25	72,5	22	40	35	-	13	-	6,3	0,5	GG-20
32.0063.02	63	2	2 ○	25	72,5	37	40	45	-	8	-	10,0	0,8	GG-25
32.0063.03	63	3	6 ●	25	72,5	52	-	52	-	-	-	13,8	1,1	GG-25
32.0063.04	63	4	6 ●	25	72,5	67	-	67	-	-	-	16,3	1,3	GG-25
32.0063.05	63	5	6 ●	25	72,5	82	-	82	-	-	-	22,5	1,8	GG-25
32.0071.01	71	1	2 ○	25	80,5	22	40	35	-	13	-	7,5	0,6	GG-20
32.0071.02	71	2	2 ○	28	80,5	37	50	45	-	8	-	12,5	1,0	GG-20
32.0071.03	71	3	6 ●	32	80,5	52	-	52	-	-	-	16,3	1,3	GG-25
32.0071.04	71	4	6 ●	32	80,5	67	-	67	-	-	-	21,3	1,7	GG-25
32.0071.05	71	5	6 ●	32	80,5	82	-	82	-	-	-	26,3	2,1	GG-30
32.0075.01	75	1	2 ○	25	84,5	22	40	35	-	13	-	8,8	0,7	GG-20
32.0075.02	75	2	2 ○	28	84,5	37	50	45	-	8	-	13,8	1,1	GG-25
32.0075.03	75	3	6 ●	32	84,5	52	-	52	-	-	-	22,5	1,8	GG-25
32.0075.04	75	4	6 ●	32	84,5	67	-	67	-	-	-	27,5	2,2	GG-25
32.0075.05	75	5	6 ●	32	84,5	82	-	82	-	-	-	33,8	2,7	GG-25
32.0080.01	80	1	2 ○	28	89,5	22	45	35	-	13	-	10,0	0,8	GG-20
32.0080.02	80	2	2 ○	32	89,5	37	50	45	-	8	-	15,0	1,2	GG-25
32.0080.03	80	3	6 ●	38	89,5	52	-	52	-	-	-	22,5	1,8	GG-25
32.0080.04	80	4	6 ●	38	89,5	67	-	67	-	-	-	28,8	2,3	GG-25
32.0080.05	80	5	6 ●	38	89,5	82	-	82	-	-	-	33,8	2,7	GG-25
32.0085.01	85	1	2 ○	28	94,5	22	45	35	-	13	-	10,0	0,8	GG-20
32.0085.02	85	2	2 ○	38	94,5	37	50	45	-	8	-	17,5	1,4	GG-25
32.0085.03	85	3	6 ●	38	94,5	52	-	52	-	-	-	23,8	1,9	GG-25
32.0085.04	85	4	6 ●	38	94,5	67	-	67	-	-	-	31,3	2,5	GG-25
32.0085.05	85	5	6 ●	38	94,5	82	-	82	-	-	-	30,0	2,4	GG-25
32.0090.01	90	1	2 ○	28	99,5	22	45	35	-	13	-	11,3	0,9	GG-20
32.0090.02	90	2	2 ○	32	99,5	37	60	45	-	8	-	21,3	1,7	GG-25
32.0090.03	90	3	6 ●	38	99,5	52	-	52	-	-	-	27,5	2,2	GG-25
32.0090.04	90	4	6 ●	42	99,5	67	-	67	-	-	-	30,0	2,4	GG-25
32.0090.05	90	5	6 ●	42	99,5	82	-	82	-	-	-	33,8	2,7	GG-30
32.0095.01	95	1	2 ○	28	104,5	22	50	35	-	13	-	12,5	1,0	GG-20
32.0095.02	95	2	2 ○	32	104,5	37	60	45	-	8	-	22,5	1,8	GG-25
32.0095.03	95	3	6 ●	38	104,5	52	-	52	-	-	-	31,3	2,5	GG-25
32.0095.04	95	4	6 ●	42	104,5	67	-	67	-	-	-	38,8	3,1	GG-25
32.0095.05	95	5	6 ●	42	104,5	82	-	82	-	-	-	47,5	3,8	GG-30
32.0100.01	100	1	2 ○	28	109,5	22	48	35	-	13	-	13,8	1,1	GG-20
32.0100.02	100	2	2 ○	32	109,5	37	60	45	-	8	-	23,8	1,9	GG-25
32.0100.03	100	3	6 ●	38	109,5	52	-	52	-	-	-	33,8	2,7	GG-25
32.0100.04	100	4	3 ●	42	109,5	67	70	50	74	-	17	36,3	2,9	GG-25
32.0100.05	100	5	3 ●	42	109,5	82	70	50	74	-	32	41,3	3,3	GG-30

● Solid pulley/Massiv skiv

○ Plate pulley/Kropskive

× Arm pulley/Egerskive

18-08-1999



A / SPA: Dm 106 – 180

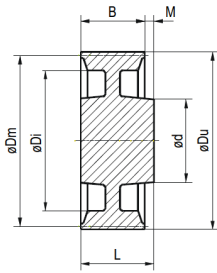

Type 2

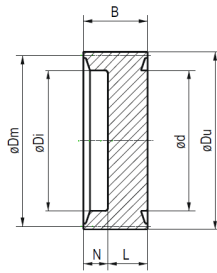

Type 3

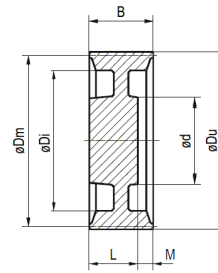

Type 5

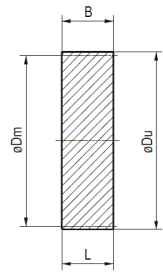

Type 6

Code	Dm	Grooves Spør	Pulley Skive	Bore Udboring	Du	B	d	L	Di	M	N	Unbalance Ubalance	Weight Vægt	Matr.
EDB	mm	no./antal	type	mm	mm	mm	mm	mm	mm	mm	mm	gcm (max)	kg	DIN1691/93
32.0106.01	106	1	2 ○	28	115,5	22	48	35	-	13	-	15,0	1,2	GG-20
32.0106.02	106	2	2 ○	32	115,5	37	60	45	-	8	-	26,3	2,1	GG-25
32.0106.03	106	3	6 ●	38	115,5	52	-	52	-	-	-	37,5	3,0	GG-25
32.0106.04	106	4	3 ●	42	115,5	67	70	50	80	-	17	40,0	3,2	GG-25
32.0106.05	106	5	3 ●	42	115,5	82	70	50	80	-	32	45,0	3,6	GG-30
32.0112.01	112	1	2 ○	28	121,5	22	48	35	-	13	-	15,0	1,2	GG-20
32.0112.02	112	2	2 ○	38	121,5	37	60	45	-	8	-	26,3	2,1	GG-25
32.0112.03	112	3	6 ●	38	121,5	52	-	52	-	-	-	42,5	3,4	GG-25
32.0112.04	112	4	3 ●	42	121,5	67	70	50	86	-	17	43,0	3,5	GG-25
32.0112.05	112	5	3 ●	42	121,5	82	70	50	86	-	32	48,8	3,9	GG-30
32.0118.01	118	1	2 ○	38	127,5	22	60	35	-	13	-	17,5	1,4	GG-20
32.0118.02	118	2	2 ○	38	127,5	37	60	45	-	8	-	26,3	2,5	GG-25
32.0118.03	118	3	6 ●	42	127,5	52	-	52	-	-	-	47,5	3,8	GG-25
32.0118.04	118	4	3 ●	42	127,5	67	70	50	92	-	17	48,8	3,9	GG-25
32.0118.05	118	5	3 ●	48	127,5	82	80	50	92	-	32	55,0	4,4	GG-30
32.0125.01	125	1	2 ○	36	134,5	22	58	35	-	13	-	20,0	1,6	GG-20
32.0125.02	125	2	2 ○	38	134,5	37	60	45	-	8	-	31,3	2,7	GG-25
32.0125.03	125	3	6 ●	42	134,5	52	-	52	-	-	-	53,8	4,3	GG-25
32.0125.04	125	4	3 ●	42	134,5	67	70	50	99	-	17	55,0	4,4	GG-25
32.0125.05	125	5	3 ●	48	134,5	82	80	50	99	-	32	61,3	4,9	GG-25
32.0132.01	132	1	2 ○	36	141,5	22	58	35	-	13	-	21,3	1,7	GG-20
32.0132.02	132	2	2 ○	38	141,5	37	60	45	-	8	-	33,8	2,9	GG-25
32.0132.03	132	3	5 ○	42	141,5	52	68	50	-	2	-	55,0	4,4	GG-25
32.0132.04	132	4	3 ●	42	141,5	67	70	50	106	-	17	60,0	4,8	GG-25
32.0132.05	132	5	3 ●	48	141,5	82	80	50	106	-	32	67,5	5,4	GG-25
32.0140.01	140	1	2 X	38	149,5	22	60	35	114	13	-	22,5	1,8	GG-20
32.0140.02	140	2	2 X	38	149,5	37	61	45	114	8	-	36,3	2,3	GG-25
32.0140.03	140	3	5 ○	42	149,5	52	68	50	-	2	-	58,8	4,7	GG-25
32.0140.04	140	4	3 ●	42	149,5	67	70	50	114	-	17	66,3	5,3	GG-25
32.0140.05	140	5	3 ●	48	149,5	82	80	50	114	-	32	75,0	6,0	GG-30
32.0150.01	150	1	2 X	38	159,5	22	60	40	124	18	-	22,5	1,8	GG-20
32.0150.02	150	2	2 X	38	159,5	37	61	45	124	8	-	28,8	2,3	GG-25
32.0150.03	150	3	5 ○	42	159,5	52	70	50	-	2	-	65,0	2,2	GG-25
32.0150.04	150	4	3 ●	48	159,5	67	80	50	124	-	17	75,0	6,0	GG-25
32.0150.05	150	5	3 ●	48	159,5	82	80	50	124	-	32	82,5	6,6	GG-25
32.0160.01	160	1	2 X	38	169,5	22	60	40	134	18	-	23,8	1,9	GG-20
32.0160.02	160	2	2 X	38	169,5	37	61	45	134	8	-	28,8	2,5	GG-25
32.0160.03	160	3	5 X	42	169,5	52	70	50	132,5	2	-	45,0	3,6	GG-25
32.0160.04	160	4	3 ●	48	169,5	67	80	50	134	-	17	87,5	7,0	GG-25
32.0160.05	160	5	3 ●	48	169,5	82	80	50	134	-	32	92,5	7,4	GG-25
32.0180.01	180	1	2 X	40	189,5	22	65	40	154	18	-	26,3	2,1	GG-20
32.0180.02	180	2	2 X	42	189,5	37	70	50	154	13	-	31,3	3,5	GG-25
32.0180.03	180	3	5 X	42	189,5	52	70	50	152,5	2	-	48,8	3,9	GG-25
32.0180.04	180	4	5 X	48	189,5	67	80	60	153	7	-	66,3	5,3	GG-25
32.0180.05	180	5	5 X	48	189,5	82	80	65	153	17	-	75,0	6,0	GG-25

● Solid pulley/Massiv skiv

○ Plate pulley/Kropskive

X Arm pulley/Egerskive

18-08-1999



A / SPA: Dm 200 – 400

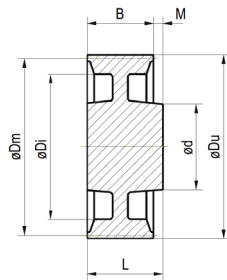

Type 2

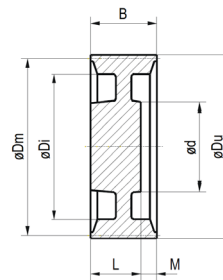

Type 5

Code	Dm	Grooves Spor	Pulley Skive	Bore Udboring	Du	B	d	L	Di	M	N	Unbalance Ubalance	Weight Vægt	Matr.
EDB	mm	no./antal	type	mm	mm	mm	mm	mm	mm	mm	mm	gcm (max)	kg	DIN1691/93
32.0200.01	200	1	2 X	38	209,5	22	65	40	174	18	-	33,2	2,5	GG-20
32.0200.02	200	2	2 X	42	209,5	37	68	50	174	13	-	43,8	3,5	GG-25
32.0200.03	200	3	5 X	48	209,5	52	77	50	172,5	2	-	62,5	4,7	GG-25
32.0200.04	200	4	5 X	55	209,5	67	90	60	173	7	-	85,1	6,4	GG-25
32.0200.05	200	5	5 X	55	209,5	82	90	65	173	17	-	90,4	6,8	GG-25
32.0225.01	225	1	2 X	38	234,5	22	65	40	199	18	-	45,0	3,0	GG-20
32.0225.02	225	2	2 X	42	234,5	37	70	50	199	13	-	46,6	4,1	GG-25
32.0225.03	225	3	5 X	48	234,5	52	77	50	197,6	2	-	75,0	5,0	GG-25
32.0225.04	225	4	5 X	55	234,5	67	90	60	198	7	-	106,5	7,1	GG-25
32.0225.05	225	5	5 X	55	234,5	82	90	65	198	17	-	121,5	8,1	GG-25
32.0240.01	240	1	2 X	42	249,5	22	70	40	214	18	-	48,0	3,0	GG-20
32.0240.02	240	2	2 X	42	249,5	37	70	50	214	13	-	61,5	4,3	GG-20
32.0240.03	240	3	5 X	48	249,5	52	77	50	212,5	2	-	88,0	5,5	GG-25
32.0240.04	240	4	5 X	55	249,5	67	90	60	213	7	-	112,0	7,0	GG-25
32.0240.05	240	5	5 X	55	249,5	82	90	65	213	17	-	128,0	8,0	GG-25
32.0250.01	250	1	2 X	46	259,5	22	75	50	224	28	-	55,1	3,3	GG-20
32.0250.02	250	2	2 X	48	259,5	37	77	50	224	13	-	68,8	4,7	GG-25
32.0250.03	250	3	5 X	48	259,5	52	77	50	222,5	2	-	91,8	5,5	GG-25
32.0250.04	250	4	5 X	55	259,5	67	90	60	233	7	-	113,6	6,8	GG-25
32.0250.05	250	5	5 X	60	259,5	82	95	65	223	17	-	148,6	8,9	GG-25
32.0280.01	280	1	2 X	42	289,5	22	70	50	254	28	-	69,2	3,7	GG-20
32.0280.02	280	2	2 X	48	289,5	37	77	50	254	13	-	78,5	4,9	GG-25
32.0280.03	280	3	5 X	48	289,5	52	77	50	252,5	2	-	119,6	6,4	GG-25
32.0280.04	280	4	5 X	55	289,5	67	90	60	253	7	-	157,1	8,4	GG-25
32.0280.05	280	5	5 X	60	289,5	82	96	65	253	17	-	181,4	9,7	GG-25
32.0300.01	300	1	2 X	46	309,5	22	75	50	274	28	-	82,0	4,1	GG-20
32.0300.02	300	2	2 X	48	309,5	37	77	50	274	13	-	91,6	5,4	GG-25
32.0300.03	300	3	2 X	55	309,5	52	90	60	272,5	8	-	160,0	8,0	GG-25
32.0300.04	300	4	5 X	55	309,5	67	88	60	273	7	-	192,0	9,6	GG-25
32.0300.05	300	5	5 X	60	309,5	82	96	70	273	12	-	206,0	10,3	GG-25
32.0315.01	315	1	2 X	46	324,5	22	75	50	289	28	-	90,3	4,3	GG-20
32.0315.02	315	2	2 X	48	324,5	37	77	50	289	13	-	108,0	5,6	GG-25
32.0315.03	315	3	2 X	55	324,5	52	90	60	287,5	8	-	163,8	7,8	GG-25
32.0315.04	315	4	5 X	55	324,5	67	90	60	288	7	-	214,2	10,2	GG-25
32.0315.05	315	5	5 X	60	324,5	82	96	70	288	12	-	241,5	11,5	GG-25
32.0355.01	355	1	2 X	42	364,5	22	75	50	329	28	-	116,1	4,9	GG-20
32.0355.02	355	2	2 X	55	364,5	37	90	60	329	23	-	117,6	7,1	GG-25
32.0355.03	355	3	2 X	55	364,5	52	90	60	327,5	8	-	201,5	8,5	GG-25
32.0355.04	355	4	5 X	55	364,5	67	90	60	328	7	-	239,4	10,1	GG-25
32.0355.05	355	5	5 X	60	364,5	82	96	70	328	12	-	296,5	12,5	GG-25
32.0400.01	400	1	2 X	50	409,5	22	80	50	374	28	-	146,8	5,5	GG-20
32.0400.02	400	2	2 X	55	409,5	37	90	60	374	23	-	168,3	8,2	GG-20
32.0400.03	400	3	2 X	60	409,5	52	96	65	372,5	13	-	208,3	7,8	GG-25
32.0400.04	400	4	5 X	60	409,5	67	96	65	373	2	-	320,4	12,0	GG-25
32.0400.05	400	5	5 X	60	409,5	82	96	70	373	12	-	379,1	14,2	GG-25

● Solid pulley/Massiv skiv

○ Plate pulley/Kropskive

× Arm pulley/Egerskive

18-08-1999



A / SPA: Dm 450 – 560

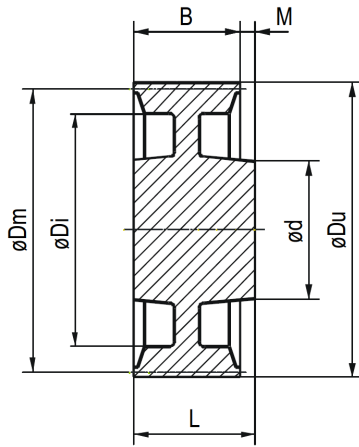

Type 2

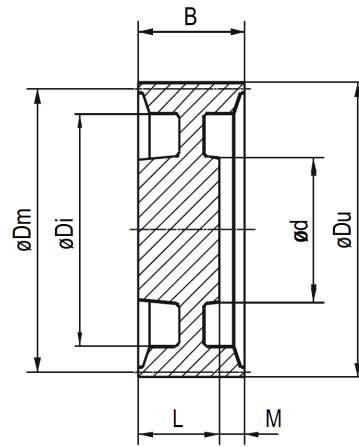

Type 5

Code	Dm	Grooves Spor	Pulley Skive	Bore Udboring	Du	B	d	L	Di	M	N	Unbalance Ubalance	Weight Vægt	Matr.
EDB	mm	no./antal	type	mm	mm	mm	mm	mm	mm	mm	mm	gcm (max)	kg	DIN1691/93
32.0450.01	450	1	2 X	52	459,5	22	85	50	424	28	-	222,0	7,4	GG-20
32.0450.02	450	2	2 X	55	459,5	37	90	60	424	23	-	218,9	11,2	GG-25
32.0450.03	450	3	2 X	60	459,5	52	96	65	422,5	13	-	336,0	11,2	GG-25
32.0450.04	450	4	2 X	65	459,5	67	105	70	423	3	-	384,0	12,8	GG-25
32.0450.05	450	5	5 X	65	459,5	82	105	70	423	12	-	474,0	15,8	GG-25
32.0500.01	500	1	2 X	52	509,5	22	85	50	474	28	-	256,4	7,7	GG-20
32.0500.02	500	2	2 X	55	509,5	37	90	60	474	23	-	339,0	12,2	GG-20
32.0500.03	500	3	2 X	60	509,5	52	96	65	472,5	13	-	439,6	13,2	GG-25
32.0500.04	500	4	2 X	65	509,5	67	105	70	473	3	-	552,8	16,6	GG-25
32.0500.05	500	5	5 X	65	509,5	82	105	70	473	12	-	629,4	18,9	GG-25
32.0560.01	560	1	2 X	52	569,5	22	85	50	534	28	-	302,1	8,1	GG-20
32.0560.02	560	2	2 X	55	569,5	37	90	60	534	23	-	406,2	13,3	GG-25
32.0560.03	560	3	2 X	60	569,5	52	96	65	532,5	13	-	626,6	16,8	GG-25
32.0560.04	560	4	2 X	65	569,5	67	105	70	533	3	-	805,7	21,6	GG-25
32.0560.05	560	5	5 X	65	569,5	82	105	70	533	12	-	902,6	24,2	GG-25



B / SPB: Dm 63 – 112

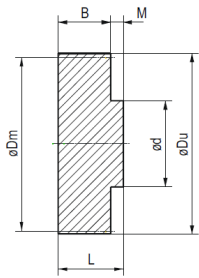

Type 1

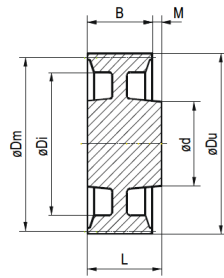

Type 2

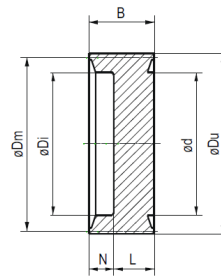

Type 3

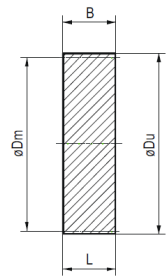

Type 6

Code	Dm	Grooves Spør	Pulley Skive	Bore Udboring	Du	B	d	L	Di	M	N	Unbalance Ubalance	Weight Vægt	Matr.
EDB	mm	no./antal	type	mm	mm	mm	mm	mm	mm	mm	mm	gcm (max)	kg	DIN1691/93
33.0063.01	63	1	1 ●	25	75,5	29	40	35	-	6	-	8,8	0,7	GG-25
33.0063.02	63	2	6 ●	25	75,5	48	-	48	-	-	-	12,5	1,0	GG-25
33.0071.01	71	1	1 ●	28	83,5	29	45	35	-	6	-	11,3	0,9	GG-25
33.0071.02	71	2	6 ●	28	83,5	48	-	48	-	-	-	16,3	1,3	GG-25
33.0071.03	71	3	6 ●	28	83,5	67	-	67	-	-	-	18,8	1,5	GG-25
33.0075.01	75	1	1 ●	28	87,5	29	45	35	-	6	-	11,3	0,9	GG-25
33.0075.02	75	2	6 ●	28	87,5	48	-	48	-	-	-	17,5	1,4	GG-25
33.0075.03	75	3	6 ●	28	87,5	67	-	67	-	-	-	23,8	1,9	GG-25
33.0080.01	80	1	2 ○	30	92,5	29	50	35	-	6	-	13,8	1,1	GG-25
33.0080.02	80	2	6 ●	30	92,5	48	-	48	-	-	-	21,3	1,7	GG-25
33.0080.03	80	3	6 ●	30	92,5	67	-	67	-	-	-	27,5	2,2	GG-25
33.0080.04	80	4	6 ●	32	92,5	86	-	86	-	-	-	36,3	2,9	GG-25
33.0080.05	80	5	6 ●	35	92,5	105	-	105	-	-	-	32,5	2,6	GG-25
33.0085.01	85	1	2 ○	30	97,5	29	50	35	-	6	-	13,8	1,1	GG-25
33.0085.02	85	2	2 ○	30	97,5	48	50	55	-	7	-	22,5	1,8	GG-25
33.0085.03	85	3	6 ●	32	97,5	67	-	67	-	-	-	31,3	2,5	GG-25
33.0085.04	85	4	6 ●	35	97,5	86	-	86	-	-	-	37,5	3,0	GG-25
33.0085.05	85	5	6 ●	35	97,5	105	-	105	-	-	-	35,0	2,8	GG-25
33.0090.01	90	1	2 ○	30	102,5	29	48	35	-	6	-	13,8	1,1	GG-25
33.0090.02	90	2	2 ○	32	102,5	48	50	55	-	7	-	23,8	1,9	GG-25
33.0090.03	90	3	6 ●	35	102,5	67	-	67	-	-	-	35,0	2,8	GG-25
33.0090.04	90	4	3 ●	38	102,5	86	65	50	60	-	36	33,8	2,7	GG-25
33.0090.05	90	5	3 ●	38	102,5	105	65	50	60	-	55	40,0	3,2	GG-25
33.0095.01	95	1	2 ○	30	107,5	29	52	35	-	6	-	17,5	1,4	GG-25
33.0095.02	95	2	2 ○	32	107,5	48	55	55	-	7	-	26,3	2,1	GG-25
33.0095.03	95	3	6 ●	35	107,5	67	-	67	-	-	-	37,5	3,0	GG-25
33.0095.04	95	4	3 ●	38	107,5	86	65	50	65	-	36	36,3	2,9	GG-25
33.0095.05	95	5	3 ●	38	107,5	105	65	50	65	-	55	45,0	3,6	GG-25
33.0100.01	100	1	2 ○	30	112,5	29	52	35	-	6	-	17,5	1,4	GG-25
33.0100.02	100	2	2 ○	32	112,5	48	55	55	-	7	-	28,8	2,3	GG-25
33.0100.03	100	3	6 ●	35	112,5	67	-	67	-	-	-	35,0	2,8	GG-25
33.0100.04	100	4	3 ●	38	112,5	86	65	50	70	-	36	40,0	3,2	GG-25
33.0100.05	100	5	3 ●	38	112,5	105	65	50	70	-	55	46,3	3,7	GG-25
33.0106.01	106	1	2 ○	30	118,5	29	48	35	-	6	-	17,5	1,4	GG-25
33.0106.02	106	2	2 ○	32	118,5	48	55	55	-	7	-	33,8	2,7	GG-25
33.0106.03	106	3	3 ●	38	118,5	67	65	50	76	-	17	37,5	3,0	GG-25
33.0106.04	106	4	3 ●	38	118,5	86	65	50	76	-	36	45,0	3,6	GG-25
33.0106.05	106	5	3 ●	38	118,5	105	67	50	76	-	55	53,8	4,3	GG-25
33.0112.01	112	1	2 ○	32	124,5	29	55	35	-	6	-	18,8	1,5	GG-25
33.0112.02	112	2	2 ○	38	124,5	48	61	55	-	7	-	36,3	2,9	GG-25
33.0112.03	112	3	3 ●	38	124,5	67	65	50	82	-	17	41,3	3,3	GG-25
33.0112.04	112	4	3 ●	42	124,5	86	75	50	82	-	36	50,0	4,0	GG-25
33.0112.05	112	5	3 ●	42	124,5	105	75	50	82	-	55	56,3	4,5	GG-25

● Solid pulley/Massiv skive

○ Plate pulley/Kropskive

× Arm pulley/Egerskive

09-08-1999



B / SPB: Dm 118 – 180

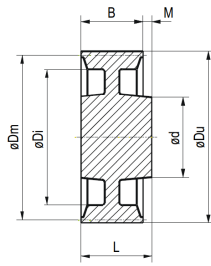

Type 2

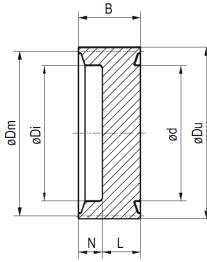

Type 3

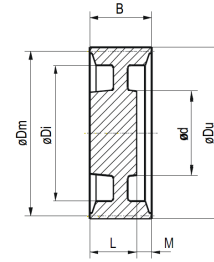

Type 5

Code	Dm	Grooves Spør	Pulley Skive	Bore Udboring	Du	B	d	L	Di	M	N	Unbalance Ubalance	Weight Vægt	Matr.
EDB	mm	no./antal	type	mm	mm	mm	mm	mm	mm	mm	mm	gcm (max)	kg	DIN1691/93
33.0118.01	118	1	2 ○	32	130,5	29	55	35	-	6	-	20,0	1,6	GG-25
33.0118.02	118	2	2 ○	38	130,5	48	60	55	-	7	-	37,5	3,0	GG-25
33.0118.03	118	3	3 ●	42	130,5	67	75	50	88	-	17	48,8	3,9	GG-25
33.0118.04	118	4	3 ●	42	130,5	86	75	50	88	-	36	53,8	4,3	GG-25
33.0118.05	118	5	3 ●	42	130,5	105	75	50	88	-	55	67,5	5,4	GG-25
33.0125.01	125	1	2 ○	32	137,5	29	58	35	-	6	-	25,0	2,0	GG-25
33.0125.02	125	2	2 ○	38	137,5	48	61	55	-	7	-	42,5	3,4	GG-25
33.0125.03	125	3	3 ●	42	137,5	67	75	50	96	-	17	53,8	4,3	GG-25
33.0125.04	125	4	3 ●	42	137,5	86	75	50	96	-	36	61,3	4,9	GG-25
33.0125.05	125	5	3 ●	42	137,5	105	75	50	96	-	55	67,5	5,4	GG-25
33.0125.06	125	6	3 ●	48	137,5	124	80	60	96	-	64	80,0	6,4	GG-25
33.0132.01	132	1	2 ○	32	144,5	29	60	35	-	6	-	23,8	1,9	GG-25
33.0132.02	132	2	2 ○	38	144,5	48	61	55	-	7	-	45,0	3,6	GG-25
33.0132.03	132	3	3 ●	42	144,5	67	75	55	103	-	12	58,8	4,7	GG-25
33.0132.04	132	4	3 ●	42	144,5	86	80	50	103	-	36	65,0	5,2	GG-25
33.0132.05	132	5	3 ●	48	144,5	105	80	60	103	-	45	81,3	6,5	GG-25
33.0140.01	140	1	2 ○	32	152,5	29	65	35	-	6	-	26,3	2,1	GG-25
33.0140.02	140	2	2 ○	38	152,5	48	65	55	-	7	-	51,3	4,1	GG-25
33.0140.03	140	3	3 ●	42	152,5	67	75	50	111	-	17	63,8	5,1	GG-25
33.0140.04	140	4	3 ●	42	152,5	86	80	50	111	-	36	73,8	5,9	GG-25
33.0140.05	140	5	3 ●	48	152,5	105	80	60	111	-	45	90,0	7,2	GG-25
33.0140.06	140	6	3 ●	48	152,5	124	80	60	111	-	64	97,5	7,8	GG-25
33.0150.01	150	1	2 ×	32	162,5	29	60	40	122	11	-	27,5	2,2	GG-25
33.0150.02	150	2	2 ×	38	162,5	48	61	55	122	7	-	40,0	3,2	GG-25
33.0150.03	150	3	3 ●	42	162,5	67	75	50	121	-	17	75,0	6,0	GG-25
33.0150.04	150	4	3 ●	42	162,5	86	80	50	121	-	36	82,5	6,6	GG-25
33.0150.05	150	5	3 ●	48	162,5	105	80	60	121	-	45	98,8	7,9	GG-25
33.0150.06	150	6	3 ●	48	162,5	124	90	60	121	-	64	108,8	8,7	GG-25
33.0160.01	160	1	2 ×	38	172,5	29	65	40	131	11	-	31,3	2,5	GG-25
33.0160.02	160	2	2 ×	42	172,5	48	68	55	131	7	-	43,8	3,5	GG-25
33.0160.03	160	3	5 ×	48	172,5	67	80	50	131	17	-	57,5	4,6	GG-25
33.0160.04	160	4	3 ●	48	172,5	86	90	60	131	-	26	105,0	8,4	GG-25
33.0160.05	160	5	3 ●	48	172,5	105	90	60	131	-	45	112,5	9,0	GG-25
33.0160.06	160	6	3 ●	55	172,5	124	90	65	131	-	59	123,8	9,9	GG-25
33.0170.01	170	1	2 ×	38	182,5	29	65	40	141	11	-	32,5	2,6	GG-25
33.0170.02	170	2	2 ×	42	182,5	48	67	50	141	2	-	46,3	3,7	GG-25
33.0170.03	170	3	5 ×	48	182,5	67	80	50	141	17	-	63,8	5,1	GG-25
33.0170.04	170	4	3 ●	48	182,5	86	90	60	141	-	26	117,5	9,4	GG-25
33.0170.05	170	5	3 ●	48	182,5	105	90	60	141	-	45	127,5	10,2	GG-25
33.0170.06	170	6	3 ●	60	182,5	124	100	65	141	-	59	145,0	11,6	GG-25
33.0180.01	180	1	2 ×	38	192,5	29	65	40	151	11	-	33,8	2,7	GG-25
33.0180.02	180	2	2 ×	42	192,5	48	68	50	151	2	-	46,3	3,7	GG-25
33.0180.03	180	3	5 ×	48	192,5	67	80	50	151	17	-	65,0	5,2	GG-25
33.0180.04	180	4	5 ×	48	192,5	86	90	60	151	26	-	92,5	7,4	GG-25
33.0180.05	180	5	3 ●	55	192,5	105	90	70	151	-	35	157,5	12,6	GG-25
33.0180.06	180	6	3 ●	60	192,5	124	100	70	151	-	54	171,3	13,7	GG-25

● Solid pulley/Massiv skive ○ Plate pulley/Kropskive × Arm pulley/Egerskive

09-08-1999



B / SPB: Dm 190 – 300

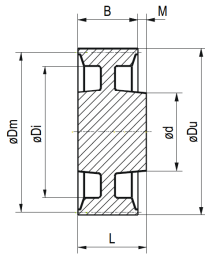

Type 2

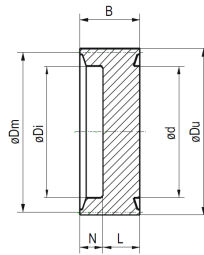

Type 3

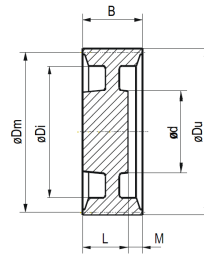

Type 5

Code	Dm	Grooves Spor	Pulley Skive	Bore Udboring	Du	B	d	L	Di	M	N	Unbalance Ubalance	Weight Vægt	Matr.
EDB	mm	no./antal	type	mm	mm	mm	mm	mm	mm	mm	mm	gcm (max)	kg	DIN1691/93
33.0190.01	190	1	2 X	38	202,5	29	65	40	161	11	-	35,6	2,8	GG-20
33.0190.02	190	2	2 X	42	202,5	48	68	50	161	2	-	49,5	3,9	GG-25
33.0190.03	190	3	5 X	48	202,5	67	80	50	161	17	-	69,9	5,5	GG-25
33.0190.04	190	4	5 X	48	202,5	86	90	60	161	26	-	90,2	7,1	GG-25
33.0190.05	190	5	5 X	55	202,5	105	90	70	161	35	-	129,5	10,2	GG-25
33.0190.06	190	6	3 ●	60	202,5	124	100	70	161	-	54	186,7	14,7	GG-25
33.0200.01	200	1	2 X	38	212,5	29	70	40	171	11	-	41,2	3,1	GG-25
33.0200.02	200	2	2 X	42	212,5	48	70	50	171	2	-	59,9	4,5	GG-25
33.0200.03	200	3	5 X	48	212,5	67	80	50	171	17	-	75,8	5,7	GG-25
33.0200.04	200	4	5 X	50	212,5	86	96	60	171	26	-	113,1	8,5	GG-25
33.0200.05	200	5	5 X	55	212,5	105	90	70	171	35	-	135,7	10,2	GG-25
33.0200.06	200	6	5 X	60	212,5	124	96	80	171	44	-	158,3	11,9	GG-25
33.0212.01	212	1	2 X	38	224,5	29	70	40	183	11	-	47,9	3,4	GG-25
33.0212.02	212	2	2 X	42	224,5	48	70	50	183	2	-	62,0	4,4	GG-25
33.0212.03	212	3	5 X	48	224,5	67	80	50	183	17	-	84,6	6,0	GG-25
33.0212.04	212	4	5 X	50	224,5	86	90	60	183	26	-	100,1	7,9	GG-25
33.0212.05	212	5	5 X	55	224,5	105	90	70	183	35	-	125,5	8,9	GG-25
33.0225.01	225	1	2 X	42	237,5	29	70	45	196	16	-	57,0	3,8	GG-20
33.0225.02	225	2	2 X	48	237,5	48	77	50	196	2	-	70,5	4,7	GG-25
33.0225.03	225	3	5 X	50	237,5	67	80	50	197	17	-	91,5	6,1	GG-25
33.0225.04	225	4	5 X	55	237,5	86	88	60	197	26	-	147,0	9,8	GG-25
33.0225.05	225	5	5 X	60	237,5	105	96	70	197	35	-	157,5	10,5	GG-25
33.0225.06	225	6	5 X	65	237,5	124	104	80	197	44	-	211,5	14,1	GG-25
33.0240.01	240	1	2 X	42	252,5	29	70	45	212	16	-	64,0	4,0	GG-25
33.0240.02	240	2	2 X	48	252,5	48	77	50	212	2	-	86,4	5,4	GG-25
33.0240.03	240	3	5 X	50	252,5	67	80	50	212	17	-	104,0	6,5	GG-25
33.0240.04	240	4	5 X	55	252,5	86	88	60	212	26	-	161,6	10,1	GG-25
33.0240.05	240	5	5 X	60	252,5	105	96	70	212	35	-	184,0	11,5	GG-25
33.0250.01	250	1	2 X	42	262,5	29	70	45	222	16	-	63,5	3,8	GG-20
33.0250.02	250	2	2 X	48	262,5	48	77	50	222	2	-	90,2	5,4	GG-25
33.0250.03	250	3	5 X	55	262,5	67	88	60	222	7	-	130,3	7,8	GG-25
33.0250.04	250	4	5 X	60	262,5	86	96	65	222	21	-	192,1	11,5	GG-25
33.0250.05	250	5	5 X	65	262,5	105	104	75	222	30	-	205,4	12,3	GG-25
33.0250.06	250	6	5 X	65	262,5	124	104	80	222	44	-	227,1	13,6	GG-25
33.0280.01	280	1	2 X	48	292,5	29	76	45	252	16	-	82,3	4,4	GG-20
33.0280.02	280	2	2 X	48	292,5	48	77	50	252	2	-	115,9	6,2	GG-25
33.0280.03	280	3	5 X	55	292,5	67	90	60	252	7	-	164,6	8,8	GG-25
33.0280.04	280	4	5 X	60	292,5	86	96	65	252	21	-	215,1	11,5	GG-25
33.0280.05	280	5	5 X	65	292,5	105	104	75	252	30	-	265,5	14,2	GG-25
33.0280.06	280	6	5 X	65	292,5	124	104	80	252	44	-	291,7	15,6	GG-25
33.0300.01	300	1	2 X	48	312,5	29	75	50	272	21	-	100,0	5,0	GG-25
33.0300.02	300	2	2 X	48	312,5	48	80	50	272	2	-	128,0	6,4	GG-25
33.0300.03	300	3	5 X	55	312,5	67	88	60	272	7	-	194,0	9,7	GG-25
33.0300.04	300	4	5 X	60	312,5	86	96	65	272	21	-	240,0	12,0	GG-25
33.0300.05	300	5	5 X	65	312,5	105	104	75	272	30	-	274,0	13,7	GG-25

● Solid pullev/Massiv skive ○ Plate pullev/Kropskive × Arm pullev/Eaerskive

09-08-1999



B / SPB: Dm 315 – 800

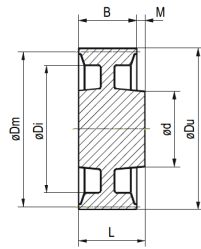

Type 2

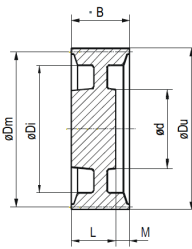

Type 5

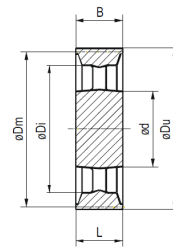

Type 7

Code	Dm	Grooves Spor	Pulley Skive	Bore Udboring	Du	B	d	L	Di	M	N	Unbalance Ubalance	Weight Vægt	Matr.
EDB	mm	no./antal	type	mm	mm	mm	mm	mm	mm	mm	mm	gcm (max)	kg	DIN1691/93
33.0315.01	315	1	2 ×	48	327,5	29	75	50	287	21	-	107,1	5,1	GG-25
33.0315.02	315	2	2 ×	55	327,5	48	88	60	287	12	-	163,8	7,8	GG-25
33.0315.03	315	3	5 ×	55	327,5	67	90	60	287	7	-	201,6	9,6	GG-25
33.0315.04	315	4	5 ×	60	327,5	86	96	65	287	21	-	252,0	12,0	GG-25
33.0315.05	315	5	5 ×	65	327,5	105	104	75	287	30	-	315,0	15,0	GG-25
33.0315.06	315	6	5 ×	75	327,5	124	120	90	287	34	-	415,8	19,8	GG-25
33.0355.01	355	1	2 ×	50	367,5	29	80	50	328	21	-	154,1	6,5	GG-20
33.0355.02	355	2	2 ×	55	367,5	48	88	60	328	12	-	229,9	9,7	GG-25
33.0355.03	355	3	5 ×	55	367,5	67	92	60	328	7	-	253,6	10,7	GG-25
33.0355.04	355	4	5 ×	60	367,5	86	96	65	328	21	-	324,5	13,7	GG-25
33.0355.05	355	5	5 ×	65	367,5	105	104	75	328	30	-	414,8	17,5	GG-25
33.0355.06	355	6	5 ×	75	367,5	124	120	90	328	34	-	549,8	23,2	GG-25
33.0400.01	400	1	2 ×	52	412,5	29	85	55	373	26	-	205,6	7,7	GG-20
33.0400.02	400	2	2 ×	55	412,5	48	88	60	373	12	-	248,3	9,3	GG-25
33.0400.03	400	3	5 ×	60	412,5	67	96	65	373	2	-	352,4	13,2	GG-25
33.0400.04	400	4	5 ×	65	412,5	86	104	75	373	11	-	491,3	18,4	GG-25
33.0400.05	400	5	5 ×	70	412,5	105	112	85	373	20	-	510,0	19,1	GG-25
33.0400.06	400	6	5 ×	65	412,5	124	120	100	370	24	-	635,5	23,8	GG-25
33.0450.01	450	1	2 ×	52	462,5	29	85	55	424	26	-	291,0	9,7	GG-20
33.0450.02	450	2	2 ×	55	462,5	48	88	60	424	12	-	333,0	11,1	GG-25
33.0450.03	450	3	5 ×	60	462,5	67	96	65	414	2	-	474,0	15,8	GG-25
33.0450.04	450	4	5 ×	65	462,5	86	104	75	424	11	-	585,0	19,5	GG-25
33.0450.05	450	5	5 ×	70	462,5	105	112	85	424	20	-	669,0	22,3	GG-25
33.0450.06	450	6	5 ×	75	462,5	124	120	100	424	24	-	840,0	28,0	GG-25
33.0500.01	500	1	2 ×	52	512,5	29	85	55	474	26	-	383,0	11,5	GG-20
33.0500.02	500	2	2 ×	60	512,5	48	96	65	474	17	-	446,0	13,4	GG-25
33.0500.03	500	3	2 ×	65	512,5	67	104	75	474	8	-	602,7	18,1	GG-25
33.0500.04	500	4	5 ×	70	512,5	86	112	85	474	1	-	629,4	18,9	GG-25
33.0500.05	500	5	5 ×	75	512,5	105	120	90	474	15	-	932,4	28,0	GG-25
33.0500.06	500	6	5 ×	80	512,5	124	128	105	474	19	-	1098,9	33,0	GG-25
33.0560.02	560	2	2 ×	60	572,5	48	96	65	535	17	-	593,1	15,9	GG-25
33.0560.03	560	3	2 ×	65	572,5	67	104	75	535	8	-	768,4	20,6	GG-25
33.0560.04	560	4	5 ×	70	572,5	86	112	85	535	1	-	932,5	25,0	GG-25
33.0560.05	560	5	5 ×	75	572,5	105	120	90	535	15	-	1081,7	29,0	GG-25
33.0630.02	630	2	2 ×	60	642,5	48	96	65	598	17	-	718,2	17,1	GG-25
33.0630.03	630	3	2 ×	65	642,5	67	104	75	597	8	-	978,6	23,3	GG-25
33.0630.04	630	4	2 ×	75	642,5	86	120	90	594	4	-	1276,8	30,4	GG-25
33.0630.05	630	5	7 ×	80	642,5	105	128	105	594	-	-	1596,0	38,0	GG-25
33.0630.06	630	6	5 ×	90	642,5	124	145	115	594	9	-	1650,6	39,3	GG-25
33.0710.02	710	2	2 ×	60	722,5	48	96	65	686	17	-	974,4	20,6	GG-25
33.0710.03	710	3	2 ×	70	722,5	67	112	85	686	18	-	1419,0	30,0	GG-25
33.0710.04	710	4	2 ×	75	722,5	86	120	90	686	4	-	1764,3	37,3	GG-25
33.0710.05	710	5	7 ×	80	722,5	105	128	105	686	-	-	2048,0	43,3	GG-25
33.0710.06	710	6	5 ×	90	722,5	124	145	115	686	9	-	2346,0	49,6	GG-25
33.0800.03	800	3	2 ×	75	812,5	67	120	90	777	23	-	1801,5	33,8	GG-25
33.0800.04	800	4	2 ×	80	812,5	86	130	105	777	19	-	2238,6	42,0	GG-25
33.0800.05	800	5	2 ×	90	812,5	105	145	115	777	10	-	2878,2	54,0	GG-25

● Solid pulley/Massiv skiv

○ Plate pulley/Kropskive

× Arm pulley/Egerskive

09-08-1999



Bores, Keyways

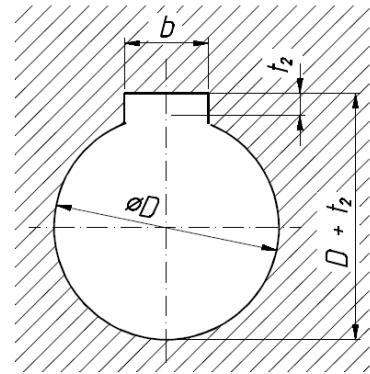
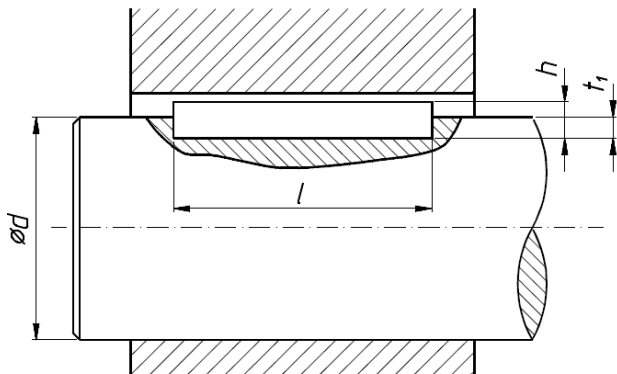

DIMENSIONS - DIMENSIONER

Diameter Diameter		Keys cross-sect. Federtværsnit b x h	Keyway depth Notdybde		Tol. for t_1/t_2
above over	up to t.o.m.		shaft aksel t_1	hub nav t_2	
mm	mm	mm	mm	mm	mm
6	8	2 x 2	1,2	1,0	+ 0,1 0
8	10	3 x 3	1,8	1,4	
10	12	4 x 4	2,5	1,8	
12	17	5 x 5	3,0	2,3	
17	22	6 x 6	3,5	2,8	
22	30	8 x 7	4,0	3,3	+ 0,2 0
30	38	10 x 8	5,0	3,3	
38	44	12 x 8	5,0	3,3	
44	50	14 x 9	5,5	3,8	
50	58	16 x 10	6,0	4,3	
58	65	18 x 11	7,0	4,4	
65	75	20 x 12	7,5	4,9	
75	85	22 x 14	9,0	5,4	
85	95	25 x 14	9,0	5,4	
95	110	28 x 16	10,0	6,4	

(ISO R 773: 1969)

FITS - PASNINGER

Type of fit Pasnings type	Keyway width Notbredde		Diameter Diameter		Characteristic of fit Pasning egenskab
	Shaft Aksel	Hub Nav	Shaft Aksel	Hub Nav	
Clearance fit Tæt løbepasn.	H8	D10	g6	H7	Movable Bevægelig
Clearance fit Glide pasning	N9	Js9	h7	H8	Easy mounting Let monterig
Push fit Easy to pull out Sugepasning Let at aftrække	P9	P9	j6	H7	For oscillation torques Til svingende momenter
Transition fit hard to pull out Let drivpasning svær at aftrække	P9	P9	k6	H7	Solid, only rarely dismounting Robust, kun ved sjældent demont.

ISO TOLERANCES - ISO TOLERANCER

Nom. diameter Nom. diameter		Bore Hul		Shaft Aksel			
above over	up to t.o.m.	H7	H8	k6	j6	g6	h7
mm	mm	μm	μm	μm	μm	μm	μm
6	10	+15 0	+22 0	+10 +1	+7 -2	-5 -14	0 -15
10	18	+18 0	+27 0	+12 +1	+8 -3	-6 -17	0 -18
18	30	+21 0	+33 0	+15 +2	+9 -4	-7 -20	0 -21
30	50	+25 0	+39 0	+18 +2	+11 -5	-9 -25	0 -25
50	80	+30 0	+46 0	+21 +2	+12 -7	-10 -29	0 -30
80	120	+35 0	+54 0	+25 +3	+13 -9	-12 -34	0 -35
120	180	+40 0	+63 0	+28 +3	+14 -11	-14 -39	0 -40
180	250	+46 0	+72 0	+33 +4	+16 -13	-15 -44	0 -46

(ISO 286-1: 1988)

- 1) Generally keys should be used, the width "b" of which is machined to a tolerance "h9".

Der bør generelt anvendes fedre, hvis bredde "b" er udført til tolerance "h9".

- 2) It is recommended, that the bearing length "l" of the key is machined to max. $l = 1,2 \times D$. A larger length does not cause an increase of torque transmission.

Federens bærende længde "l" anbefales udført til max. $l = 1,2 \times D$. En større længde medfører ingen forøgelse af momentoverførselen.

- 3) For reversing operation, and when heavy shock loads occur, it is recommended that the pulley is mounted with an interference fit.

Til reverserdrift og ved forekomst af kraftigt stødende momenter anbefales, at remskiven monteres med en prespasning.

- 4) The pulleys are bored by using the diameter "Du" for set up.

Remskiverne udbores ved at anvende diameter "Du" til onsnænding.



Specifications

GROOVE DIMENSIONS / SPOR DIMENSIONER

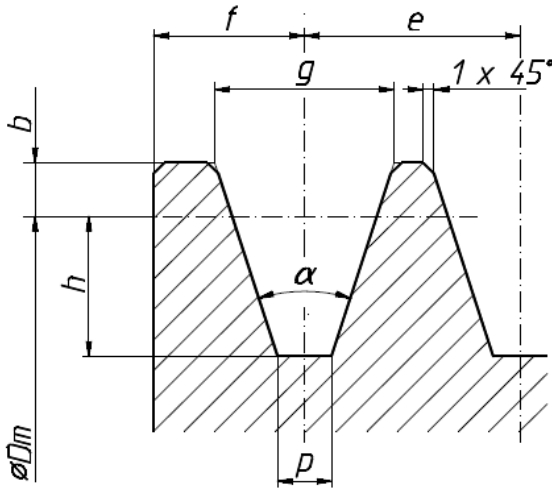

	Dm mm	ang.	g mm	h mm	b mm	f mm	e mm	p mm
S/SPZ	≤ 80	34°	9,72	7,5	3,5	8	12	3
	> 80	38°	9,88					2,3
A/SPA	≤ 118	34°	12,68	9	4,75	11	15	4,27
	> 118	38°	12,89					3,43
B/SPB	≤ 190	34°	16,14	11,25	6,25	14,5	19	5,44
	> 190	38°	16,41					4,36
C	≤ 315	34°	22,6	10,5	9,5	19	26	10,4
	≤ 500	36°	23,0					10,0
	> 500	38°	23,3					9,5

MATERIAL

All cast iron used for the V-belt pulleys is electrically melted quality cast iron. This gives the iron an increased degree of purity and quality. Electrically melted iron contains only a minimum of contaminating matters as e. g. phosphor and sulphur. Therefore it has a very close-grained structure without microporosities. Because of the high degree of purity, gas holes in the cast iron are avoided.

BALANCING

V-belt pulleys with solid hub are supplied with a max. static unbalance, balanced in one plane, according to quality grade G40 ¹⁾. Upon request the pulleys can be supplied balanced in two planes, dynamic unbalance, according to quality grade G40 or G16.

¹⁾ Designation according to ISO 1940

PACKING

V-belt pulleys are zinkphosphated and oiled. They are not separately packed. Upon request V-belt pulleys with solid hub can be delivered with desired bore and keyway.

MATERIALE

Alt støbegods, der er anvendt til kileremskiver, er elektrosmeltet kvalitetsstøbejern. Dette giver jernet en større renhed og højere kvalitet. Elektrosmeltet jern indeholder kun minimale mængder af forureningsstoffer bl. a. fosfor og svovl. Det har derfor en meget tæt struktur uden mikroporositeter, og på grund af den høje renhedsgrad undgås gashuller i godset.

AFBALANCERING

Kileremskiver uden udboing leveres med en max. ubalance i et plan, kvalitetsgrad G40 ¹⁾. Efter ønske kan kileremskiver leveres afbalanceret i to planer, kvalitetsgrad G40 eller G16.

¹⁾ Betegnelse i henhold til ISO 1940

EMBALLAGE

Kileremskiver er zinkfosfaterede med en efterfølgende oliering. De er ikke særskilt emballeret. Kileremskiver kan ved bestilling leveres med ønsket udboing og notgang.